



The **PETKUS Seed Cleaner K 542** is used for high-quality seed cleaning of free flowing bulky products, e.g. pulses which do not need to be processed with an indented cylinder. Furthermore, the seed cleaner can also be used for the intensive cleaning of grain, oilseeds, and pulses. The high standard of cleaning is achieved by a combination of the screening system and the air aspiration.

#### Advantages:

- Suitable for various products due to extensive setting options.
- High standard of cleaning
- Simple and quick changing of screens
- Two different air volume ranges adjustable for various products
- Highly effective cleaning of the screen surfaces by screen agitators (top screen) and brushes (bottom screen)

#### Description:

The product is moved from the inlet hopper through the pre-aspiration duct. Light rejects, husk and dust are separated here.

Afterwards, the product is transported to the screen compartment. The top screen separates large and coarse rejects. The top screen is cleaned with a screen agitator. Light rejects are separated by the bottom screen. A brush carriage cleans the bottom screen.

The screened product is transported through the final aspiration duct. Further light rejects with lower density are separated there by the air flow.

The cleaned products are transported to the discharge and can be bagged-off there.

#### Construction:

The seed cleaner K 542 is equipped with an inlet hopper, one pre- and final aspiration duct with depositing chambers, a screen compartment with two screen layers. The various components of the machine (inlet hopper, screen compartments, fan etc.) are operated by a V-belt system with an electric motor.

#### Standard Equipment:

- Bolted housing made of painted sheet steel
- One set of screens for one screening diagram
- Equipment with screen agitators and brush carriage
- Drive unit with 3.0 kW electric motor

#### Options:

- Screens available for a large number of different products
- Adaptation to specific customer requirements possible

# Seed Cleaner Type K 542

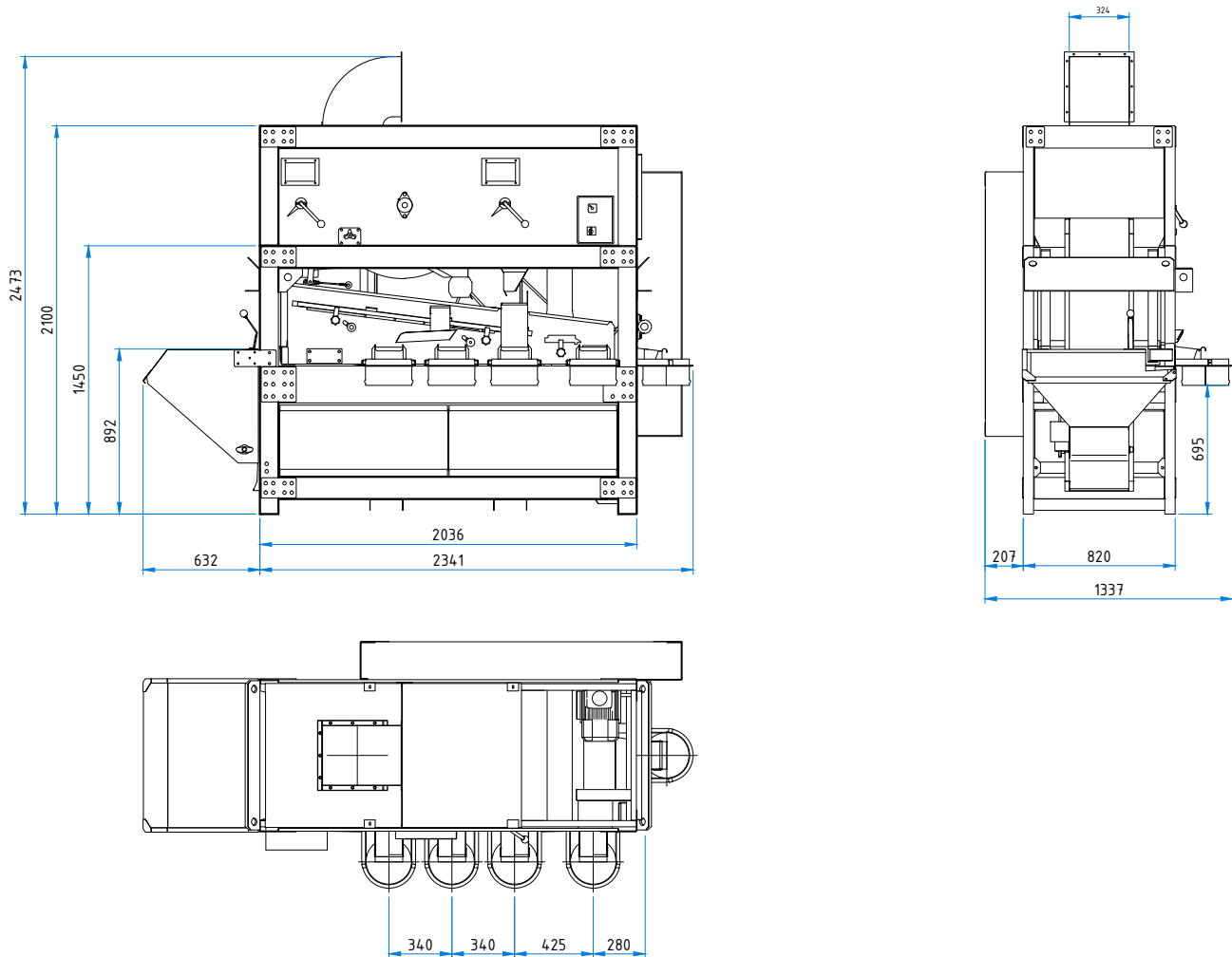

Technical Data		K 542		Technical Data		K 542	
Capacity (Based on: Wheat)				No. of Screen layers	pcs.	2	
Industrial cleaning	t/h	1,75		Upper screen layer	pc.	1	
Seed cleaning	t/h	1,25		Lower screen layer	pc.	1	
				Cleaning of upper screen layer		Knocker	
				Cleaning of lower screen layer		Brushes	
Working width	mm	630		Dimension			
Screen area	m <sup>2</sup>	1,25		Length	mm	2914	
Air volume 1	m <sup>3</sup> /h	4500		Width	mm	1337	
Air volume 2	m <sup>3</sup> /h	5800		Height	mm	2100	
Drive motor	kW	3,0		Total height with pipe connection	mm	2473	
Revolution	U/min	1450		Air exhaust system			
Revolution of the fan 1	U/min	900		Diameter Pipe for exhaust system	mm	450	
Revolution of the fan 2	U/min	1100		Cyclon type	FKA	1250/1600	
Weight	kg	ca. 920					

Technical alteration reserved.