



**PETKUS bucket elevators** are used for the vertical transport of granular and free flowing bulky products, e.g. grain, pulses, oilseeds and similar agricultural products.

#### Advantages:

- Modular design through duct lengths of 500 mm, 1000 mm and 2000 mm
- Easy assembly and maintenance
- Suitable for the transport of seed (option)
- Optimal transport for each product through the individual adaptation of the bucket elevator (different bucket designs, speed adjustment, motor capacity etc.)
- Low space requirement because of the compact design

#### Description:

The product to be conveyed is vertically transported from the inlet in the elevator foot up to the outlet spout in the elevator head. The transport is performed by a bucket system screwed on the conveying belt.

#### Construction:

The bucket elevator is equipped with an elevator head, elevator foot, and the elevator ducts. A gear motor drives the conveying belt with the buckets over a belt pulley in the elevator head. A second belt pulley in the elevator foot is used as a tail pulley and for tightening the conveying belt. The lower belt pulley is designed as a tail pulley in order to avoid breaking and damaging the product.

#### Standard Equipment:

- Galvanized sheet steel
- Elevator head with drive unit, back stop device and outlet
- Elevator foot with one-sided inlet clamping device and discharge slide
- Elevator ducts including conveying belt and bucket system

#### Options:

- Speed monitoring
- Off-track running sensor
- Dust extraction pipe
- Capacity slide
- Model for the transport of seed
- Elevated elevator foot with discharge box
- Platform with ladder
- Explosion relief in various models

# Bucket Elevator Type BE 100

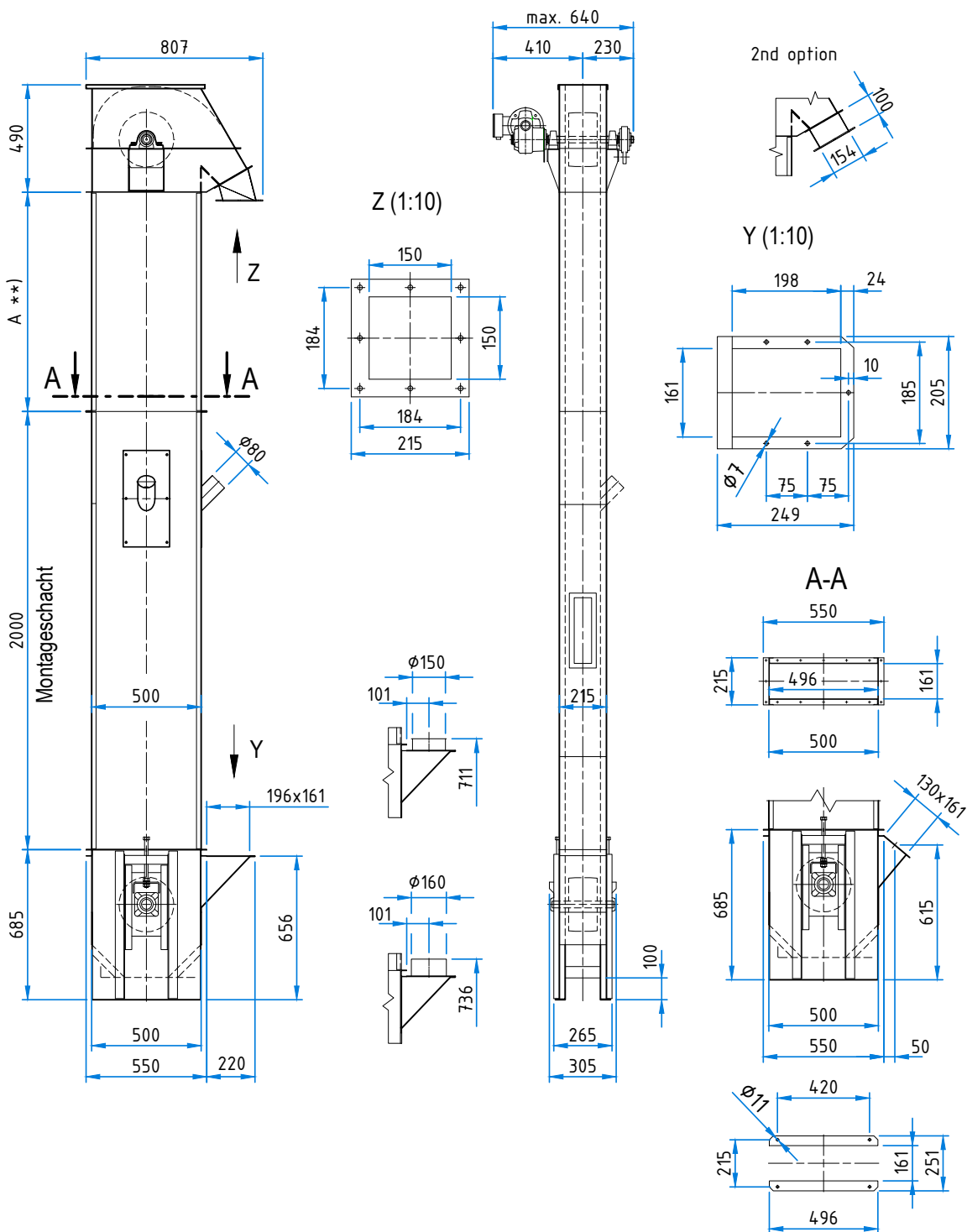

Technical alteration reserved.