

PETKUS bucket elevators are used for the vertical transport of granular and free flowing bulky products, e.g. grain, pulses, oilseeds and similar agricultural products.

Advantages:

- Modular design through duct lengths of 500 mm, 1000 mm and 2000 mm
- Easy assembly and maintenance
- Suitable for the transport of seed (option)
- Optimal transport for each product through the individual adaptation of the bucket elevator (different bucket designs, speed adjustment, motor capacity etc.)
- Low space requirement because of the compact design

Description:

The product to be conveyed is vertically transported from the inlet in the elevator foot up to the outlet spout in the elevator head. The transport is performed by a bucket system screwed on the conveying belt.

Construction:

The bucket elevator is equipped with an elevator head, elevator foot, and the elevator ducts. A gear motor drives the conveying belt with the buckets over a belt pulley in the elevator head. A second belt pulley in the elevator foot is used as a tail pulley and for tightening the conveying belt. The lower belt pulley is designed as a tail pulley in order to avoid breaking and damaging the product.

Standard Equipment:

- Galvanized sheet steel
- Elevator head with drive unit, back stop device and outlet
- Elevator foot with one-sided inlet clamping device and discharge slide
- Elevator ducts including conveying belt and bucket system

Options:

- Speed monitoring
- Off-track running sensor
- Dust extraction pipe
- Capacity slide
- Model for the transport of seed
- Elevated elevator foot with discharge box
- Platform with ladder
- Explosion relief in various models

Bucket Elevator Type BE 130 / BE 180 / BE 280

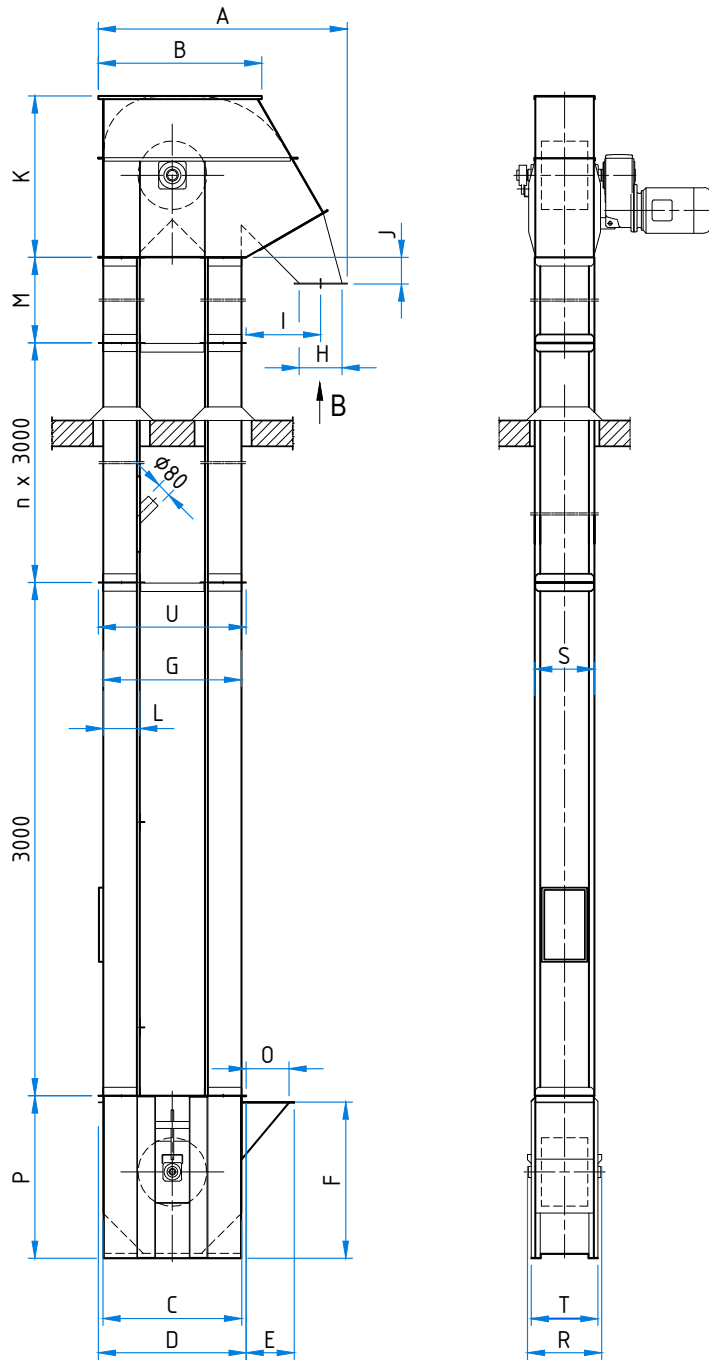

mm	a	b	c
BE 130	117	200	265
BE 180	135	250	315
BE 280	167	300	365

Type	A	B	C	D	E	F	G	H	I	J	K	L	O
	mm	mm	mm	mm	mm	mm	mm	mm	mm	mm	mm	mm	mm
BE 130	1175	777	660	714	250	763	658	200	325	105	747	188	220x208
BE 180	1455	955	810	854	280	913	807	250	435	155	943	213	250x283
BE 280	1645	1052	952	1004	310	1044	948	300	450	150	1122	234	280x356

	Diameter belt disc, mm					
	P	R	S	T	U	
BE 130	300	800	348	273	314	714
BE 180	400	950	433	348	389	804
BE 280	500	1080	508	422	484	948

Technical alteration reserved.